

Father & Child LED Floor lamp - 3299894

Assembly and User Instructions – Please keep for future reference

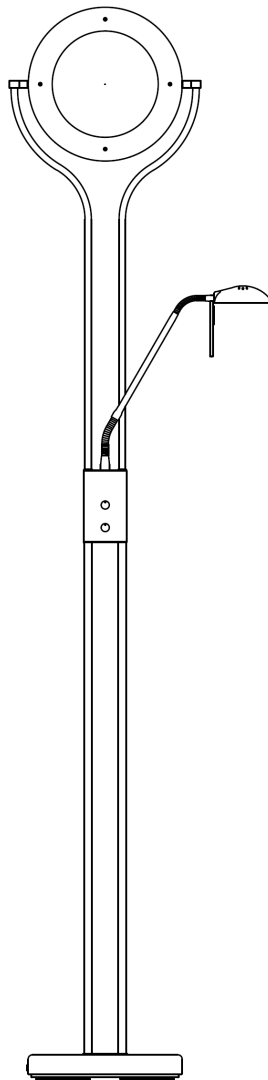

Important –Please read these instructions fully before using
If you need help please call our **Customer Services** on 0345 640 3030

Contents

Section	Page
Parts and Component list	2
Safety Information	3
Maintenance	3
Installation	4

Produced for ARGOS,
Argos Limited, London, EC1N 2HT, UK
Argos (NI) Ltd, Belfast, BT8 6FX, UK

Parts and Components Listing

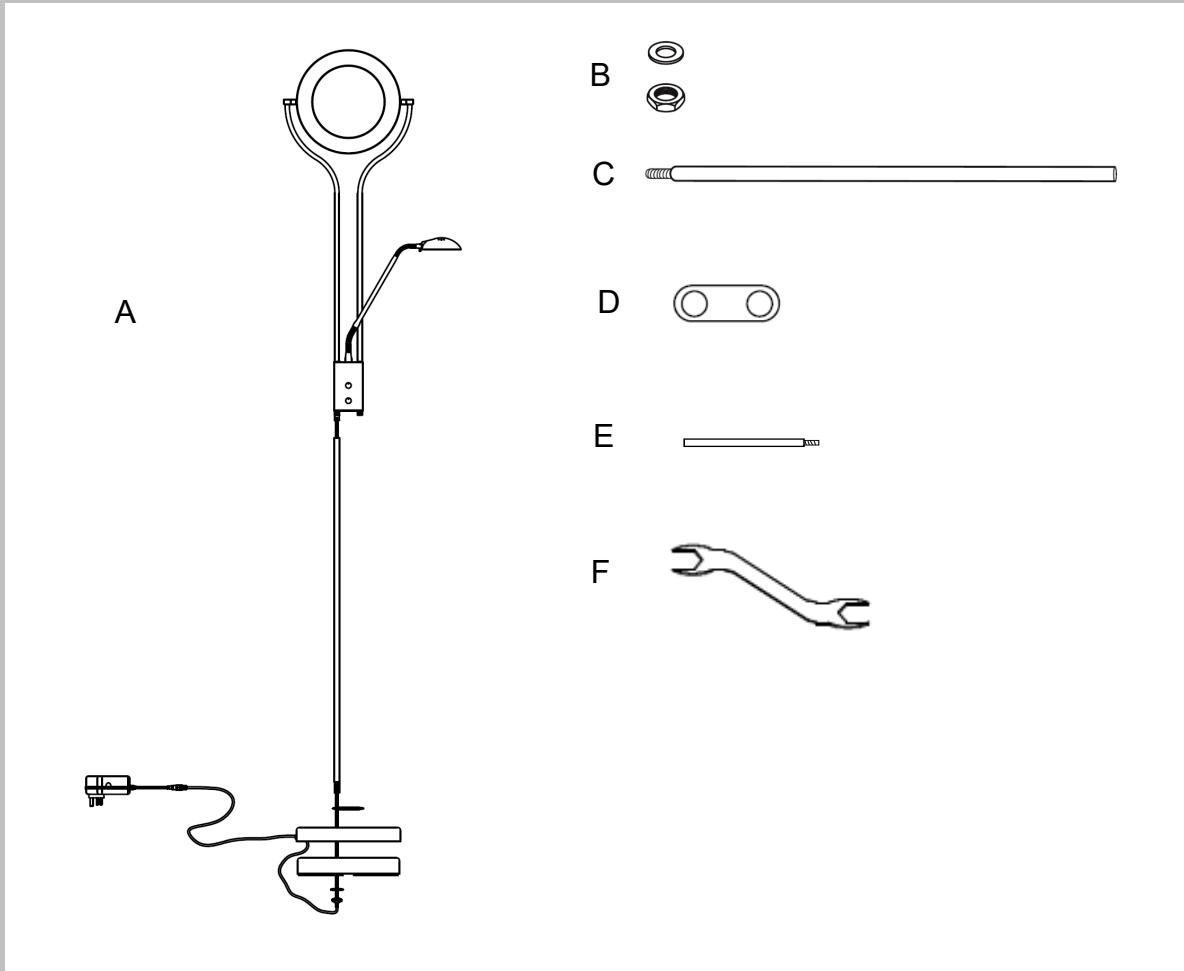

- A. Fitting x 1 (pre-wired + UK transformer plug attached)
- B. Fixing nuts & Washers x 2 (1 pre-fitted), not assembled)
- C. Pole x 2 (1 pre-fitted, not assembled)
- D. Poles base washer x 1 (Pre-fitted, not assembled)
- E. Adjusting Arm for Child lamp x 1
- F. Spanner x 1

Safety Information

IMPORTANT – Please read these instructions fully before installation and keep for future reference

For your safety, this product must be installed in accordance with local building Regulations. If in any doubt, or where required by law, consult a competent person who is registered with an electrical self certification scheme. Further information is available online or from your local authority.

IMPORTANT -This product has been designed for non-professional, domestic use only.

IMPORTANT - Carefully unpack and examine the product for any damage. If you think there is a defect, **do not** use the product and contact our customer services on **0345 640 3030**.

IMPORTANT - Dispose of all packaging correctly and responsibly and in accordance with all local laws and regulations. Never leave packaging components within reach of children as they can be a source of danger.

IMPORTANT – The integrated LED lamps cannot be replaced.

WARNING – This is a Class 3 product and not requires an earth connection.

WARNING – Do not modify or alter any product before or after installation. This may render the product un-safe.

WARNING - Accessible parts become hot during use, young children **must** be kept away.

WARNING - This product is not intended for use by persons (including children) with reduced physical, sensory and mental capabilities, or lack of experience and knowledge, unless they have been given supervision or instruction concerning use of the product by persons responsible for their safety.

WARNING - Children should be supervised to ensure that they do not play with the product.

WARNING - **Do not** place this fitting in a damp atmosphere.

WARNING - **If the external flexible cable or cord if this Luminaire is damaged this luminaire shall be destroyed.**



Maintenance

CAUTION! Always disconnect power supply when servicing or cleaning.

Cleaning

- Use a clean dry soft or slightly damp cloth.
- Do not use abrasive cloths or polishes as this may cause damage to the product.

Additional Information

This product contains 2 light sources of energy efficiency class F.

The UK LED transformer plug can be replaced by a professional.

The Integrated LED lamps cannot be replaced, when the LED lamps reach the end of their life the whole luminaire shall be replaced.

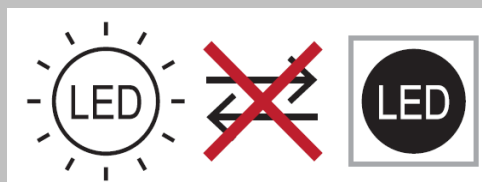
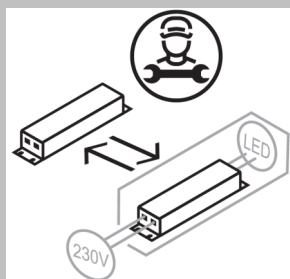

Installation

Installation

IMPORTANT ! - Electrical connections must be carried out by a suitably qualified person and in accordance with all relevant local building and installation regulations. If in doubt consult a qualified electrician.

Installation

1. Screw the lower poles onto the bottom of the switch section taking care not to twist or damage the cable from the pole pre-fitted on the product.
2. Place the base washer onto the pole screws.
3. Place the base cover onto the pole screws.
4. Place the base weight onto the pole screws and under the base cover.
5. Attach the washer and lock nuts onto the pole screws.
6. Using the spanner tool provided screw the hex nut to secure poles and base cover and base weight in place, pull the excess of the cable out of the base.
7. Screw the adjusting arm to the child lamp as illustrated.
8. Connect the plug to a normal household socket.
9. Using the 2 rotary on/off dimming switches from the fitting, switch on the lamps and test the product.

